

RAA-70 SERIES



◆ Feature

Specially divided
B.C.D Code/Binary Code

◆ Application

CNC Machine (Tool changer)

Out Dimensions

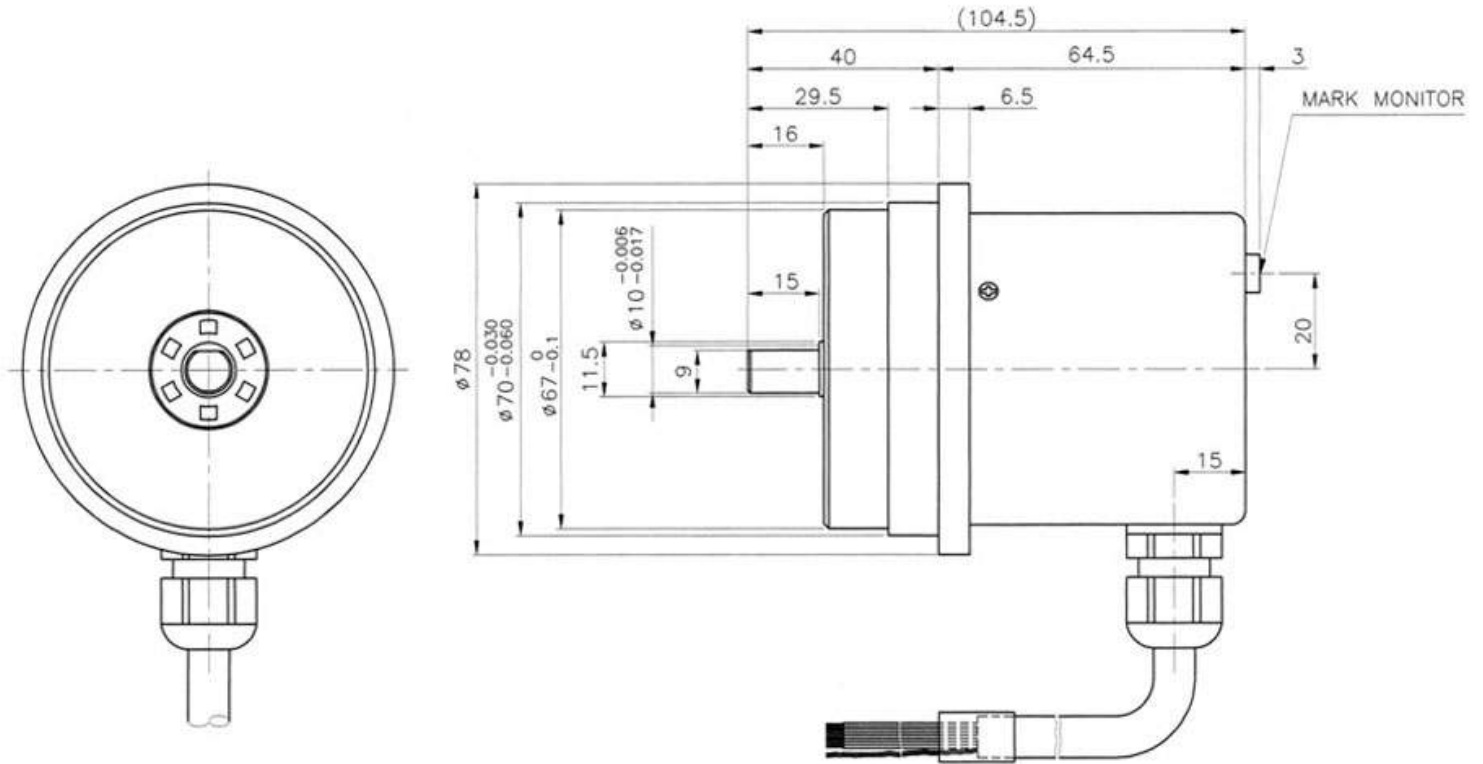



Specification



Electrical Spec.

Resolution	8/10/12/16 P/R	
Supply Voltage	DC+24V	
Current Consumption	PNP	120 mA MAX
	NPN	80 mA MAX
Max. Response Frequency	20 kHz MAX	
Rising/Falling Time	PNP	3 μS
	NPN	3 μS

Mechanical Spec.

Maximum Rotating Speed	5,000 rpm	
Starting Torque	200gf•cm MAX at 25 °C	
Moment of Inertia	30gf•cm² Max	
Allowable Shaft Load	Radial	5kg Max
	Axial	5kg Max
Vibration Resistance	10 ~ 55Hz / 1.5mm	
Shock Resistance	50G, 11msec	
Operation Temp. Range	-10 °C ~ +60 °C	
Storage Temp. Range	-20 °C ~ +80 °C	
Protection	IP64	

출력 회로

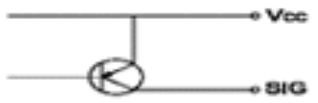

PNP Open-Collector

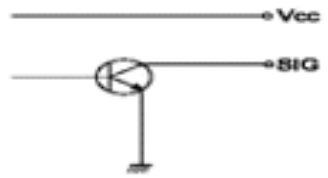

NPN Open-Collector

출력 코드

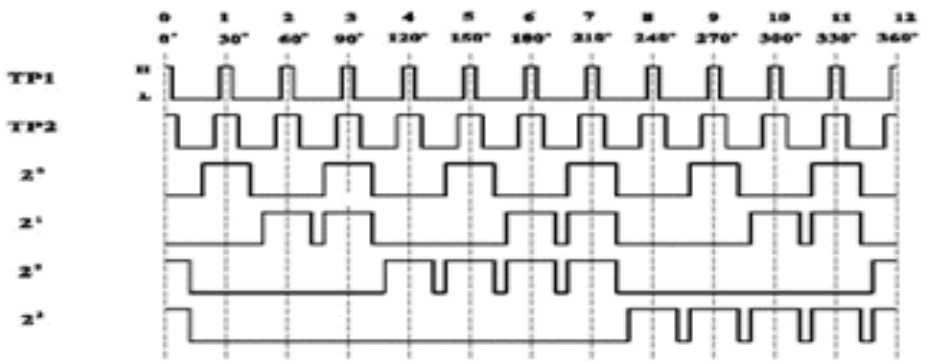

BINARY CODE

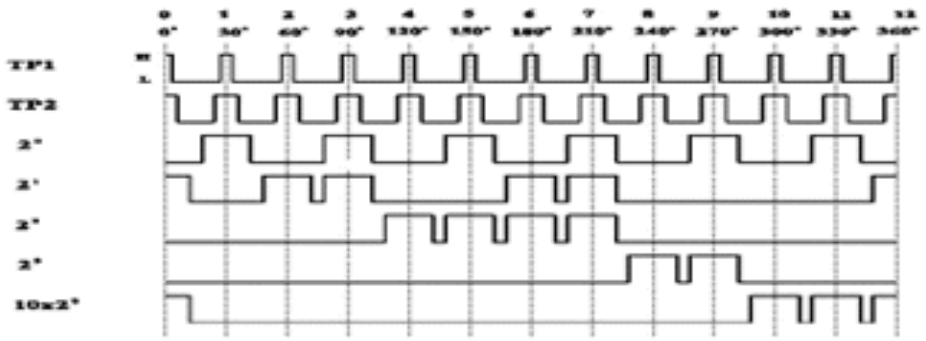

BCD CODE